

INSTRUCTION MANUAL

COFFEE GRINDER

PK 100

SHOP

LAB

COMPAK



CONTENTS



COFFEE GRINDER

PK 100

SHOP / LAB

SAFETY	4
DESCRIPTION	6
INSTRUCTIONS	7
IDENTIFICATION	8
TECHNICAL CHARACTERISTICS	9
EXTERNAL COMPONENTS	11
INSTALLATION	12
OPERATION	16
CLEANING	20
MAINTENANCE	22
EC DECLARATION OF CONFORMITY	25

1. SAFETY

ADDITIONAL SAFETY MEASURES BUILT-IN TO OUR GRINDERS:

- **Special screw to keep the hopper fixed.**
 - **Access restriction for the grinding unit.**
-



This coffee grinder should be used exclusively for the functions for which it has been designed: **to grind coffee beans.**



Do not use the mill to grind other types of foods such as nuts or to grind finer granulated foods such as sugar and others



This device **may be used by children aged 8 years and over, by people with reduced physical, sensory or mental capacities and by people without prior experience/knowledge**, provided they have received supervision or instructions on the safe use of the device and understand the associated risks.



Children should not play with the device.



Cleaning and maintenance of the device should not be carried out by children without supervision.



Avoid allowing liquids to come into contact with internal or external surfaces while the appliance is switched ON or OFF, except for those parts expressly mentioned in the "CLEANING" section. If, for any reason, this happens, unplug it immediately from the mains and dry all surfaces carefully.

1. SAFETY

USERS SHOULD PAY SPECIAL ATTENTION TO AND SCRUPULOUSLY OBEY THE FOLLOWING SAFETY INSTRUCTIONS



If it is necessary to access the interior, where the electrical components are located please **go to the nearest technical service centre.**



If any component should break or any intervention is needed, we recommend contacting the **technical service centres**, which will carry out the repair or replacement, guaranteeing that safety standards are adhered to.



Only an **authorized supplier** may replace the main cable of any grinder.



Any other use will be considered improper and dangerous



When handling burrs, special care should be taken as they **could cut**. The use of suitable gloves is recommended



NOTE: The manufacturer will not be liable for damages caused either by the improper use of the device or by not following the stated safety measures.

2. DESCRIPTION



The coffee grinder you have purchased has been designed using the most innovative technological systems.

For the best results from the grinders described in this manual, the maximum operating/resting times are:

Model	Work cycle	
	ON	OFF
PK 100 SHOP/LAB	1'	3'

The result is a high quality product that ensures the best results. Our products are manufactured entirely by hand, one at a time, following the most demanding quality requirements.

In its manufacturing process, quality materials (aluminium, steel, etc.) are used, which are suitable for contact with food.

SOUND LEVEL

The sound level produced by this model is:

Sound level	With coffee
PK 100 SHOP/LAB	75 dB



3. INSTRUCTIONS

3.1. This manual provides the information needed for **correct installation, handling and maintenance of the device and**



emphasises the precautions that must be borne in mind by the operator.

Example: (1) - 1 Single dose cupping

Icons:

Information	Warning

To ensure you get the best out of coffee grinders, it is essential to carefully follow the instructions given in this manual.

If there is any kind of problem, contact the nearest technical service. This manual should be kept until the machine is replaced and must always be available to the operator.

3.2. This manual uses some special terms, such as:

- **Text in bold** to highlight the importance of some terms.
- **Numbers in parentheses after a word, which match the numbering of the items** in the image to the side or in the image of the external components.

4. IDENTIFICATION



The technical characteristics plate is indelibly marked with the following information:

COMPAK[®] COFFEE GRINDING COMPANY Made in Spain		TECEE CB SCHEME	CE
MODEL		SERIAL NUMBER	
LAB/SHOP	DATE	ORDER	
ELECTRICAL DATA			
CICLES			
COMPAK Coffee Grinders s.a Moli Barri, B, P.i. Can Barri 08415 Bigues, Barcelona, Spain. IPX1 COFFEE GRINDER			



NOTE: The manufacturer reserves the right to change the machine components, according to the requirements of each market, and also for technological advances.

5. TECHNICAL CHARACTERISTICS

5.1. SCOPE

The coffee grinders are intended for use on commercial premises and facilities where ground coffee is required, or in small stores that sell coffee, but not for continuous mass production of food.



This grinder should only be used to grind coffee beans.

Any other use is considered improper and dangerous.

i NOTE: The manufacturer is not liable for damage to persons, goods or the machine itself, if the safety regulations given in this manual are not followed, or the machine is used incorrectly.

5. TECHNICAL CHARACTERISTICS

5.2. TECHNICAL DATA

		100 V 60 Hz	110 V 60 Hz	220 V 60 Hz	230 V 50 Hz	240 V 50 Hz	
PK100 SHOP/LAB	Electrical power	960	960	750	750	750	W
	Rotational velocity	1.100	1.100	900	900	900	rpm

Model	Ø Flat burrs		Espresso grinding		Filter grinding		Time for one dose (5,5 g) Espresso
	mm	in	g/min	lb/min	g/min	lb/min	
PK100 SHOP/LAB	98	3.86	350	0,77	600	1,32	1
	mm	in	g/min	lb/min	g/min	lb/min	s

Model	Time for one dose(10gr) Filter	Single dose cupping/ hopper capacity		Net weight		Height Width Depth
		g	lb	Kg	lb	
PK100 LAB	1	55	0,12	25,4	55	622 252 328
PK100 SHOP	1	750	1,54	24,3	53,5	690 252 328
	s	g	lb	Kg	lb	mm

6. EXTERNAL COMPONENTS



14

*PK100 Shop Hopper



7. INSTALLATION

7.1. LEGAL NOTICES

 The installer must read this instruction manual carefully before installing the machine.



The installation of the device must be carried out by qualified and authorised personnel, obeying all the current safety and hygiene regulations.

7.2. IMPORTANT WARNINGS

 The operator must be a responsible adult. Never a child nor someone without the ability to accept that responsibility.

When handling the grinder, the following precautions should be obeyed:

- Feet must not be bare.
- Hands and feet must be dry.
- Do not get the machine wet.
- Do not expose the machine to direct sunlight or other atmospheric agents.
- **Never insert any object into the coffee inlet or outlet while the appliance is running.** (Please remember that when the grinder stops, the milling cutters will keep turning for a short while).
- **When unplugging the grinder, always pull on the plug and never the power cable to avoid a possible short circuit.**

7. INSTALLATION

7.3. WHERE TO USE IT

i The appliance must be installed on a solid. Flat surface.



The minimum size for the working space, to ensure you get the best performance from the machine, must be the following:

	SHOP	LAB	
Height	730 26.1	662 28.7	mm in
Height	257 10.12	257 10.12	mm in
Depth	333 13,11	333 13,11	mm in

7.4. INSTALLING THE COFFEE GRINDER

Before connecting the coffee grinder, check the following:

- The characteristics on the data plate match those of the electrical mains network.
- The electrical connection plug matches the socket into which it is to be plugged.
- Ensure that the electrical power of the facility is adequate for the power consumed by the appliance.
- The point of connection to the electrical mains network must be protected with the appropriate electrical protection device.
- The equipment must be correctly connected to a ground connection according to the current safety regulations.

7. INSTALLATION

7.5 POSITIONING THE HOPPER AND/OR SINGLE DOSE CUPPING

Loosen the fixing screw (8) (Fig. 3).

FOR THE HOPPER

Place the hopper (14) on the upper body (3), press down and turn clockwise until its position is fixed. (Fig. 4 y 5).

FOR THE SINGLE DOSE CUPPING

Place the single dose cupping (1) on the upper body, checking that the handle (2) is on the right side, and press down. (Fig. 4).

Then fix the hopper or the single dose cupping with the fixing screw. (Fig. 3).

i **NOTE:** The manufacturer reserves the right to change the machine components, according to the requirements of each market, and also for technological advances.



Fig. 3

7. INSTALLATION



8. OPERATION

8.1. POWER SWITCH

The power switch (12) has 2 positions, ON – OFF

ON : Equipment on

OFF : Equipment OFF

8.2. USE

The grinders are factory calibrated, establishing optimal grinding ranges. The selector (13) on the front grinding adjustment knob (4) indicates, on a scale from 0 to 900, the degree of grinding, 0 being the finest and 900 the coarsest. Turn the front adjustment knob (4) clockwise for a finer coffee or counterclockwise for a thicker coffee.











PK100 LAB

To grind coffee: Pour in the amount of coffee beans that you want to grind.

Place the receptacle in the portafilter fork. Turn on the grinder with the GRIND / CLEAN button and set the desired grind point.

! NOTE: This operation must always be carried out without coffee inside the grind chamber to avoid blocking/jamming.

Then open the bean gate, let all the coffee fall into the grind chamber, and close the bean gate. Once the coffee has been ground into the receptacle, firmly press and release the spring-loaded handle 2 or 3 times so that any residual coffee falls out. Remove the receptacle and turn off the equipment once the process is finished.

1 GRINDING FINENESS		
		100 - 300 particles <i>French Press</i>
		500 - 800 particles <i>Filter, Percolator</i>
		1.000 - 3.000 particles <i>Drip</i>
		3.500 particles <i>Espresso</i>
		15.000 - 35.000 particles <i>Turkish</i>

! NOTE: The amount of coffee ground in a given time will vary depending on the fineness of the grinding.

8. OPERATION

PK100 SHOP

To grind coffee: Pour in the amount of coffee beans that you want to grind.

Place the receptacle in the portafilter fork. Turn on the grinder with the GRIND / CLEAN button and set the desired grind point.

NOTE: This operation must always be carried out without coffee inside the grind chamber to avoid blocking/jamming.

Then open the bean gate, let all the coffee fall into the grind chamber, and close the bean gate. Once the coffee has been ground into the receptacle, firmly press and release the spring-loaded handle 2 or 3 times so that any residual coffee falls out. Remove the receptacle and turn off the equipment once the process is finished.

NOTE: In the event of a possible blockage/jam of the grind adjustment knob: Turn on the equipment with the Grind/Clean button. Turn the grind adjustment dial counterclockwise until it stops turning (all the way to the coarsest setting). Firmly press and release the spring-loaded handle 2-3 times.

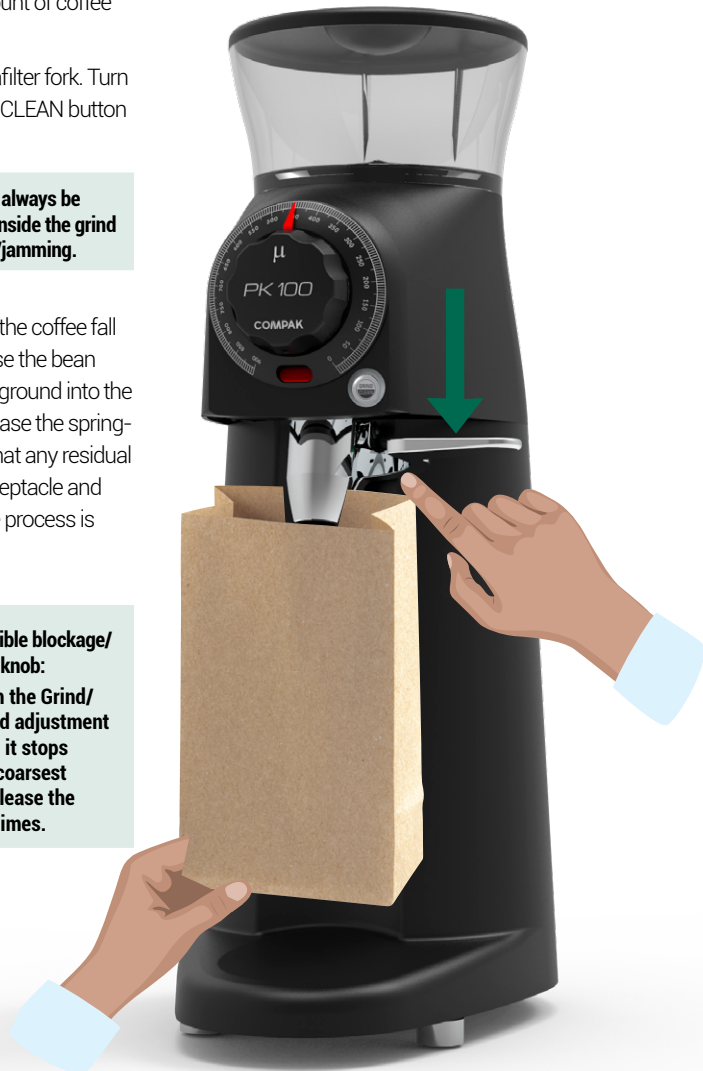

Fig. 6

8. OPERATION

8.3. ADJUSTMENT OF PK 100 LAB PORTAFILTER HOLDER

The standard configuration is useful for most portafilter holders on the market. However, depending on the geometry of each filter holder, it can be adjusted as follows for a good fit:

1. Release the portafilter spring clamp, for this, release the screw that fixes them to the holder with the help of a star-head screwdriver (**Fig.3**).
2. The springs clamps have an A and a B engraved on the inside.
3. Once the springs clamps have been removed, mount them in the opposite position to that they were in when they arrived, i.e. the A where the B was and the B where the A was to get the adjustment so that the filter holder fits and is held proper.

For filter holders with diagonal wings, the standard portafilter spring clamp must be replaced by the ones supplied separately.

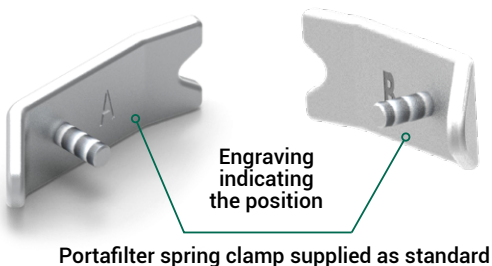
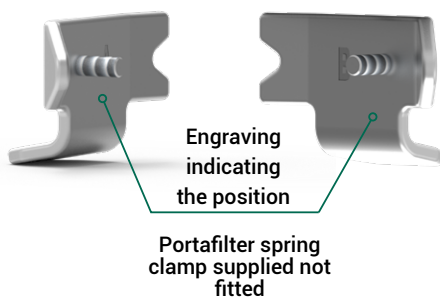

i NOTE: The PK holder is not adjustable.

8. OPERATION



Fig. 3

9. CLEANING

9.1. GENERAL CLEANING

To guarantee proper operation of the grinder, as well as good quality ground coffee, it is necessary to periodically clean the parts that come into contact with the coffee.

- To clean the machine:
- Always turn off the grinder at the power switch (12).
- Disconnect the machine from the power supply
- Do not submerge the grinder in water or use power washing devices.
- The appliance is not to be cleaned with a water jet or a steam cleaner.

9.2. CLEANING THE COFFEE BEAN HOPPER/ SINGLE DOSE CUPPING

To clean the single dose cupping/ hopper thoroughly (1) first, all the coffee in the hopper must be used up. Remove the single dose cupping as shown in section 8.

The cupping (1) can be washed with a damp cloth or with soap and water to remove the oily residues produced by the coffee, rinse it thoroughly and dry it.

To refit the coffee bean hopper (1) onto the grinder, follow the steps described above in reverse.

9.3. CLEANING THE GRINDING CHAMBER

We recommend cleaning the coffee grinding chamber weekly with a Compak cleaning product. This has the advantage of eliminating the remains of coffee and the oils, which can go off and spoil the quality of the coffee. The steps to follow are these

- Grind the coffee left inside the grinding chamber
- Put 60 g of the cleaning product into the cupping (1).
- Grind up all the Compak cleaning product to a medium fineness so it works properly
- Clean the hopper (1) and fill with coffee.
- Throw away the first 2-3 doses of coffee and adjust the grinder to the desired fineness (4).

After following these instructions, the grinder will be clean and ready to work.

9. CLEANING

We do not recommend dismantling the grinding system, except to carry out a burrs change operation, which must be carried out by a qualified technician because of the precision required during the operation.

9.4. CLEANING THE COFFEE NOZZLE

It is very important to continue cleaning the coffee outlet (7) in order to ensure consistency in the doses and the best quality ground coffee. Use a tubular brush for that cleaning.

i Notice: It is recommended to do this cleaning at least once a month.

9.5. CLEANING THE EXTERIOR

For exterior cleaning, first use a dry brush and then a cloth lightly moistened with soap and water.

! NOTE: Not carrying out these cleaning operations will negatively affect the flavour and aroma of the coffee.



Fig. 8

10. MAINTENANCE

10.1. GENERAL NOTICE

Before performing any type of maintenance operation:

- Always switch off the grinder at the power switch (12) putting it into the OFF position.
- If the machine is blocked, disconnect the equipment from the mains and contact the authorised technical service.
- Unplug it from the mains network.

In the event of a fault or malfunction, turn off the device, never try to repair it, it is essential to call the nearest technical service.



Failure to comply with this warning can compromise the safety of both the device and the user.

10.2. GENERAL MAINTENANCE

As well as the cleaning operations described in the previous section, in order to ensure the grinder operates well and to ensure the best quality of ground coffee, periodic and preventive maintenance of the milling unit must be carried out by the qualified technical service.

Burrs in poor condition lead to poor quality ground coffee as they get very hot, and they also lead to higher electrical power draw by the equipment.



NOTE: Based on the accumulated experience and assuming the use of medium hardness coffee mixtures, we suggest replacing the burrs according to the following table:

	Steel
LAB/SHOP	9000 Kg

10. MAINTENANCE

10.3. MAINTENANCE OF THE GRINDING UNIT

NOTE: These operations must be carried out by the qualified technical service.

To carry out the maintenance of the grinding area, the following instructions should be followed:

- Turn the front adjustment dial (4) to the left, until it stops.
- Turn off the grinder using the main switch (12).
- Unplug the grinder from the power source.
- Remove the Single dose cupping hopper (1) from the upper body (3) according to **section 8.2**.
- Remove the upper body plate (3), unscrewing the two rear screws.
- Remove the fixing screws (a) from the upper burr assembly using an Allen key 4, as per (Fig. 9).
- Block the lower burr holder and unscrew with an Allen key 6, turning clockwise, the screw in the center of the burr. Remove the screw and washer..
- Insert a screwdriver through the side opening of the grind chamber casing and apply an upward force to raise the lower burr holder (Fig. 10).
- Once the burr holder is raised, tap with a nylon hammer right in the center of the burr, where the motor sleeve is located. This will lower and release the burr holder.
- Remove the lower burr.
- Remove the worn burrs by unscrewing them from their upper and lower burr holders with a Phillips screwdriver.

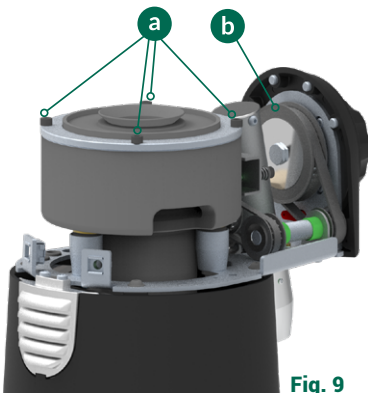

Fig. 9

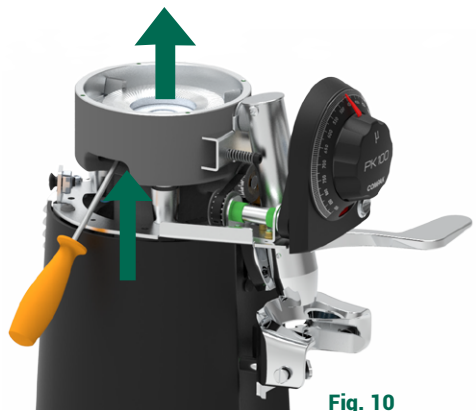

Fig. 10

10. MAINTENANCE

- Clean the burr holders of any coffee residue.
- Replace the worn burrs and tighten the 4 screws, of both burr holders, in an X shape (Fig. 11).



Fig. 11

- Reassemble the fixing screws (a) of the upper burr holder to the grind chamber.
- Set point "0" of burrs, section 10.4.

10.4. RESET THE BURRS TO THE 0 / CALIBRATION

The 0 position of the burrs is the point where they will lightly touch and will make a slight hum.

By following these instructions, small changes to the grind setting can be made.

- Ensure the 0 point setting. Turning the front adjustment knob (4) clockwise until the burrs lightly touch and emit a humming sound.

! If they do not lightly touch and make a slight humming sound, follow these steps:

- Without removing it, loosen the screw (b) (Fig. 12) with the help of the supplied wrench.
- Insert the wrench between the pulley and the internal frame plate and use a slight lever to separate them just a bit.

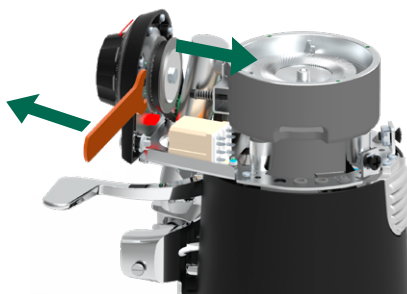

Fig. 12

- Turn the adjustment knob (4) clockwise, approx. 30 degrees, and retighten the screw (b) (Fig. 12).
- Turn the adjustment knob (4) clockwise to ensure that the burrs touch at point 0 on the adjustment knob dial.
- If they do not touch burrs, repeat the process, until the burrs touch at point 0.
- Assemble the upper body (3), tighten the fixing screws.
- Position Single Dose Cupping (1) / Hopper (14), on the upper body (3) according to section 7.5.

11. DECLARATION OF CONFORMITY

Quality certificates have been applied in accordance with European Community regulations. All the technical materials have been suitable and are ready and available in our offices.

2014/30/EU on the harmonisation of the laws of the Member States relating to electromagnetic compatibility.

2006/42/EC on machinery and amending Directive 95/16/EC.

REG. 1935/2004 on materials and articles intended to come into contact with food and repealing Directives 80/590/EEC and 89/109/EEC.

2003/108/EC amending Directive 2002/96/EC on waste electrical and electronic equipment (WEEE).

2014/34/EU on the harmonisation of the laws of the Member States relating to equipment and protective systems intended for use in potentially explosive atmospheres.

2012/19/EU of **04/07/12** on waste electrical and electronic equipment (WEEE).

11/65 / EU on the restriction of the use of certain hazardous substances in electrical and electronic equipment.



Environment

When disposing of this appliance, do not throw it away with the normal household waste, deposit it at an official collection point for recycling. In doing so, you will contribute to preserving the environment.

The Legal Representative

Jesús Ascaso



Compak Coffee Grinders, s.a.

Molí Barri, Parcela B - Pol. Ind. Can Barri - 08415 Bigues i Riells - Barcelona - Spain
Ph. 34 93 703 13 00 - Fax 34 93 703 13 23 - www.compak.es

NOTES

.....

.....

.....

.....

.....

.....

.....

.....

.....

.....

.....

.....

.....

.....

.....

.....

.....

.....

.....

.....

.....

.....

.....

NOTES

.....

.....

.....

.....

.....

.....

.....

.....

.....

.....

.....

.....

.....

.....

.....

.....

.....

.....

.....

.....

.....

.....

.....

COMPAK



Original Instructions
Quality Process Ref. 002/03 | v. 31/05/2022 | K07179H06



CONTACT

Molí Barri, Parcela B
Polígono Industrial Can Barri
08415 Bigues i Riells
Barcelona - Spain

Phone: +34 93 703 13 00

Fax: +34 93 703 13 23

E-mail: info@compak.es

Website: www.compak.es

